

# NVG79D & E Series Low Power DIP OCXO

## Description:

Bliley's low power DIP OCXOs are designed for portable applications where low start-up and idling current are required to preserve battery life.

This series of OCXOs has fast warm-up times, are available with various input supply voltages and have excellent frequency vs. temperature performance.

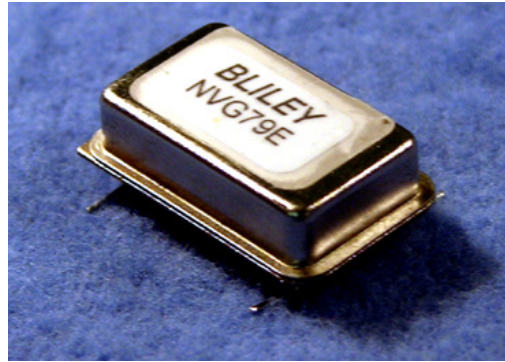

## Features:

- Low Input current during warm-up <250mA
- Warm-up Time as low as <10 Seconds
- Power Input at steady state <0.4 watts
- Standard Frequencies available; 10MHz, 12.8MHz, 16MHz, 16.384MHz, 19.44MHz, 20MHz, 26MHz, and 40MHz
- Consult Factory for other Frequencies available

## Frequency Range:

Output Frequency Range	20 KHz to 54MHz
------------------------	-----------------

## Frequency versus Temperature:

Operating Temperature	Temperature Range Options	Frequency Stability (Block Tolerance)
0°C to 60°C	Option A	0.05ppm
-20°C to +70°C	Option B	0.10ppm
-40 to +85 °C	Option C	0.20ppm

## Typical Specifications:

Parameter	Specification	Units
Supply Voltage	+3.3VDC & +5VDC	
Output Signal	<b>Option A - Sine Wave</b>	
Frequency <20MHz	>0.8	V <sub>pp</sub>
Frequency >20MHz	>0.63	V <sub>pp</sub>
Output Load	50	Ω
Supply Voltage	3.3   5   12	VDC
Output Signal	<b>Option B - HCMOS Compatible</b>	
Level "0"	<0.4	V
Level "1"	>V <sub>cc</sub> - 0.5V   4.5 - 5.0	V
Rise & Fall Time	<7	nS
Duty Cycle	50±5	%
Output Load	1KΩ    5pF	

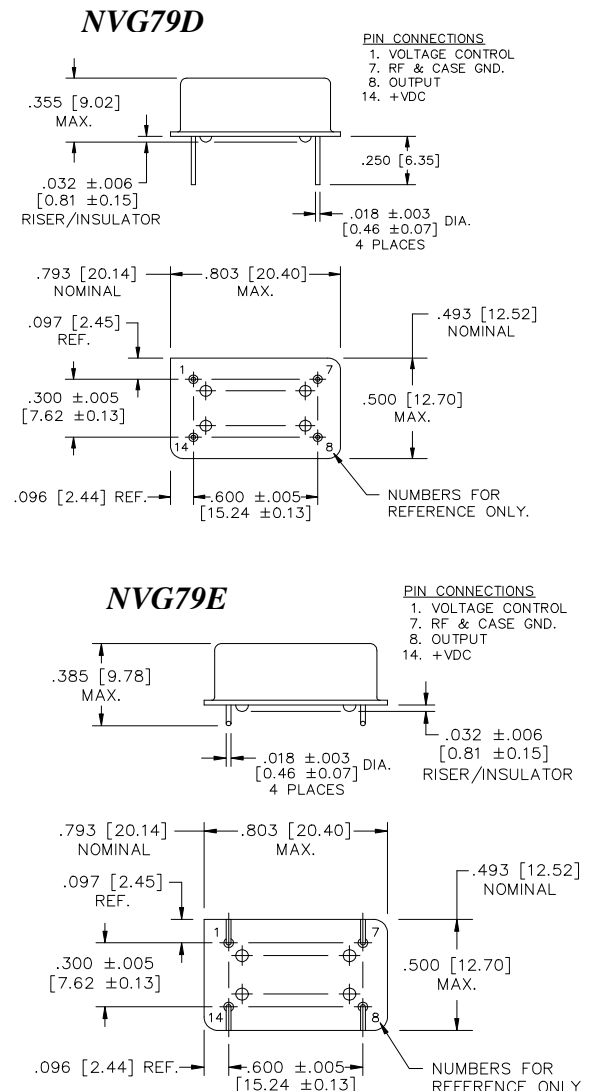

# NVG79D & E Series Low Power DIP OCXO

## Typical Specifications ...continued

Parameter		Units
Aging		
1 <sup>st</sup> Year	±0.3	ppm
10 Years	±2.5	ppm
Short Term Stability		
0.1 Sec to 30 Sec	<5 x 10 <sup>-10</sup>	
Typical @ 1 Sec	5 x 10 <sup>-11</sup>	

Parameter		Units
Freq Stability vs. Supply Voltage; 5% Change	±0.1 Max ±0.04 Typical	ppm
Frequency Stability vs. Load Change; 10% Change	±0.01 Max ±0.006 Typical	ppm

### Phase Noise Performance:

Typical @ 10MHz	HCMOS Output	Sine Wave Output	Units
Offset from Carrier			
1 Hz	-70	-75	dBc/Hz
10Hz	-100	-110	dBc/Hz
100Hz	-130	-135	dBc/Hz
1KHz	-140	-145	dBc/Hz
10KHz	-145	-150	dBc/Hz

### Electronic Frequency Control:

Voltage Control Range	Supply Voltage +3.3VDC	Supply Voltage +5.0VDC	Supply Voltage +12VDC	Units
0.0 – 3.3 VDC	>±2.5	----	----	ppm
0.5 – 5.0 VDC	----	>±2.5	>±2.5	ppm

### Power Supply Characteristics:

	Option "A"	Option "B"	Option "C"	Units
Input Voltage	+3.3	+5	+12	VDC
Input Current @ 30°C	<110	<80	<30	mA
Input Current @ -20°C	<170	<120	<45	mA
Turn-on Current	<250	<250	<250	mA
Warm-up Time	30	10	10	Seconds

### Ordering Options:

	Package Style	Temperature Range	Output Type	Power Supply	Operating Frequency (MHz)
NVG79 (ROHS Compliant)	D	A	A	A	XXMXXX
	E	B	B	B	XXMXXX
		C		C	XXMXXX

**NVG79**

**D**

**B**

**A**

**B**

**16M384**